

**JUMO GmbH & Co. KG**  
Delivery address: Mackenrodtstraße 14,  
36039 Fulda, Germany  
Postal address: 36035 Fulda, Germany  
Phone: +49 661 6003-0  
Fax: +49 661 6003-607  
e-mail: mail@jumo.net  
Internet: www.jumo.net

**JUMO Instrument Co. Ltd.**  
JUMO House  
Temple Bank, Riverway  
Harlow, Essex CM 20 2TT, UK  
Phone: +44 1279 635533  
Fax: +44 1279 635262  
e-mail: sales@jumo.co.uk  
Internet: www.jumo.co.uk

**JUMO Process Control, Inc.**  
8 Technology Boulevard  
Canastota, NY 13032, USA  
Phone: 315-697-JUMO  
1-800-554-JUMO  
Fax: 315-697-5867  
e-mail: info@jumo.us  
Internet: www.jumo.us



# JUMO dTRANS p02 Pressure transmitter

## Type 404385

 II 1/2G EEx ia IIC T4-T6

## General application

The pressure transmitter Type JUMO dTRANS p02 is used to measure the gauge (relative) and absolute pressures of corrosive and non-corrosive gases, vapours and liquids. The measuring device for the pressure transmitter is a piezo-resistive element or thin-film strain gauge. The output signal is a proportional DC current which is linearly proportional to the input pressure. In the version "with Ex protection Ex II 1/2G EEx ia IIC T4-T6", the pressure transmitter can be mounted within the hazardous Zone 1, for connection to Zone 0. For special applications, e.g. for measuring highly viscous media, the JUMO dTRANS p02 is available with flush pressure connections in various styles. Suitable pressure connections are also available for applications involving media temperatures of up to 200°C.

### The display visualises

- the pressure in 13 different units, measurement in % or scaled with a freely adjustable dimensional unit, output current in mA
- the sensor temperature in °C
- measurement error, out-of-range measurement
- minimum and maximum pressures (peak-reading indicator)
- pressure and sensor temperature can be displayed simultaneously (on two lines)

### The operating keys can be used to set

- start and end of range with pressure input
- start and end of range without pressure input (blind setting)
- damping or time constant
- current generator function
- output signal on error
- key inhibit
- reset minimum and maximum measured value (peak-reading indicator)
- density correction for different media being measured
- display of the temperature of the medium, in °C or °F

The pressure transmitter JUMO dTRANS p02 can also be operated using a HART® communicator or a PC in connection with a HART® modem and the JUMO setup program running under Windows®.



## Accessories

### Setup program

Sales No. 40/00365072

The setup program for all instruments in the JUMO dTRANS p02 series has been created according to the VDI/VDE 2187 user interface. In conjunction with the HART® modem, the program enables convenient operation and parameter setting of the pressure transmitter from a PC.

### HART® modem

Sales No. 40/00345666

The HART® modem is used to link the JUMO dTRANS p02 pressure transmitter to the serial interface of a PC.

### Pressure separator

for adaptation to special situations where the usual pressure connections cannot be used. See Data Sheets 40.9770 to 40.9786.

### Isolated supply for Ex applications, HART®-capable

Sales No. 40/00389710,  
See Data Sheet 40.4757

## Technical data

### Explosion protection (only with basic type extension 1)



II 1/2G EEx ia IIC T4-T6

PTB 98 ATEX 2194

The supply must be intrinsically safe and must not exceed the following maximum values:

$U_i = DC 30V$

$I_i = 100mA$

$P_i = 750mW$

### Reference conditions

to DIN 16 086 and IEC 770/5.3

### Nominal ranges

see ordering details

### Range setting

The measurement range can be set from the transmitter keys, by using the setup program or a HART® communicator as described below:

Start and end of range can be continuously adjusted within the nominal range. The span should not be less than 10% of the nominal range..

### Units that can be visualised

Input pressure:

in mH<sub>2</sub>O, inH<sub>2</sub>O, inHg, ftH<sub>2</sub>O, mmH<sub>2</sub>O, mmHg, psi, bar, mbar, kg/cm<sup>2</sup>, kPa, Torr, MPa

Measurement:

in %, or scaled with a freely adjustable dimensional unit

Output current:

in mA

### Additional displays

Indication of the sensor temperature, minimum pressure, maximum pressure, indication of overrange and on error

### Density correction

adjustable within the range from 0.100 to 5.000 kg/dm<sup>3</sup>

### Overload limit

to DIN 16 086

-1 bar and 4 x full scale or

-1 bar and 2 x full scale with ranges  $\geq 100$ bar

### Bursting pressure

to DIN 16 086

10 x full scale; 2 000bar max.

### Parts in contact with the medium

standard:

stainless steel, Mat. Ref. 1.4435, 1.4571

for range  $\geq 100$ bar

stainless steel, Mat. Ref. 1.4571, 1.4542

### Pressure connection

see ordering details

### Output

4 – 20mA max. burden ( $U_B - 11.5V$ ) / 22mA

burden with HART® 1100Ω max., 250Ω min.

with HART® protocol V 5.3.

Complies with the guidelines of the HCF (HART® Communication Foundation)

### Burden error

$< 0.1\%$

### Zero offset / adjustment accuracy

$\leq 0.01mA$

### Ambient temperature error

within range -20 to +85°C

(compensated temperature range)

zero: 0.005%/°C typical,

0.01%/°C max.

span: 0.005%/°C typical,

0.01%/°C max.

### Deviation from characteristic

for limit setting:

not exceeding 0.1% of full scale of nominal range; to DIN 16 086

### Hysteresis

For nominal ranges  $\geq 100$ bar

$\leq 0.05\%$  of full scale; to DIN 16 086

For nominal ranges  $\leq 25$ bar

$\leq 0.02\%$  of full scale; to DIN 16 086

### Repeatability

For nominal ranges  $\geq 100$ bar

$\leq 0.05\%$  of full scale; to DIN 16 086

For nominal ranges  $\leq 25$ bar

$\leq 0.02\%$  of full scale; to DIN 16 086

### Response time

approx. 150msec, without damping

### Damping

adjustable 0 to 100 s

### Stability per year

$\leq 0.1\%$  of full scale (for nominal range with reference conditions to IEC 770)

### Supply

11.5 – 36V DC

11.5 – 30V DC (for intrinsically safe version)

Supply units for output signal transmission with or without HART® communication, in intrinsically safe version, see Data Sheet 40.4757.

### Note:

at least 17V DC (250Ω) for communication via HART® protocol.

### Supply voltage error

$\leq 0.1\%$  of full scale per 10V change

(nominal supply voltage 24V DC)

### Permitted ambient temperature

-40 to +85°C; to DIN 16 086

(the LCD display cannot be read at temperatures below -20°C)

With version EX II 1/2G EEx ia IIC T4-T6:

+60°C

### Storage temperature

-40 to +85°C

### Permitted temperature of medium

-40 to +120°C for the standard version

-40 to +200°C for basic type extension 4

### Electromagnetic compatibility

to EN 61326

### Mechanical shock

50g/11 msec

### Mechanical vibrations

5g max. at 10 – 2000Hz

### Protection

with connecting cable

IP65 to EN 60 529

### Isolation resistance

100MΩ; 50V DC

### Breakdown strength

$\geq 500V_{eff}$ .

### Housing

aluminium die-casting GDAISI12

### Climatic conditions

$\leq 80\%$  rel. humidity annual mean, with condensation

### Electrical connection

clamping case with screw cover, 2-pole and earth terminal, plastic cable gland M20 x 1.5 for cable cross-section 6 to 12mm

### Nominal position

factory set upright vertical (pressure connection below) operating position is unrestricted

### Weight

approx. 1.3kg

### HART® communication

#### between PC and transmitter

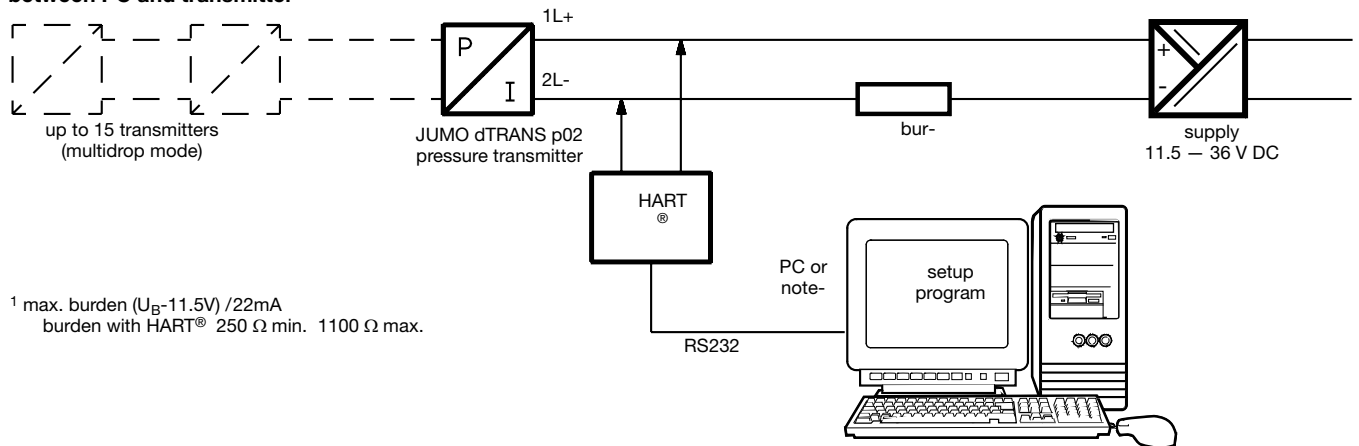

<sup>1</sup> max. burden ( $U_B$ -11.5V) / 22mA  
burden with HART® 250 Ω min. 1100 Ω max.

#### between HART® communicator and transmitter

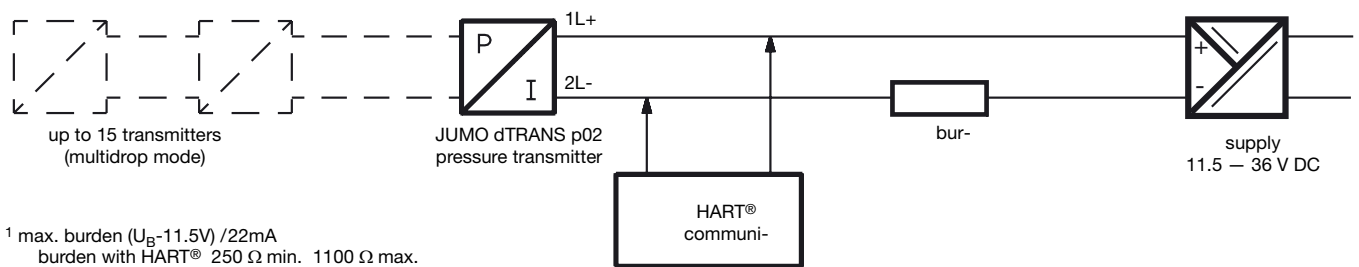

<sup>1</sup> max. burden ( $U_B$ -11.5V) / 22mA  
burden with HART® 250 Ω min. 1100 Ω max.

### Dimensions

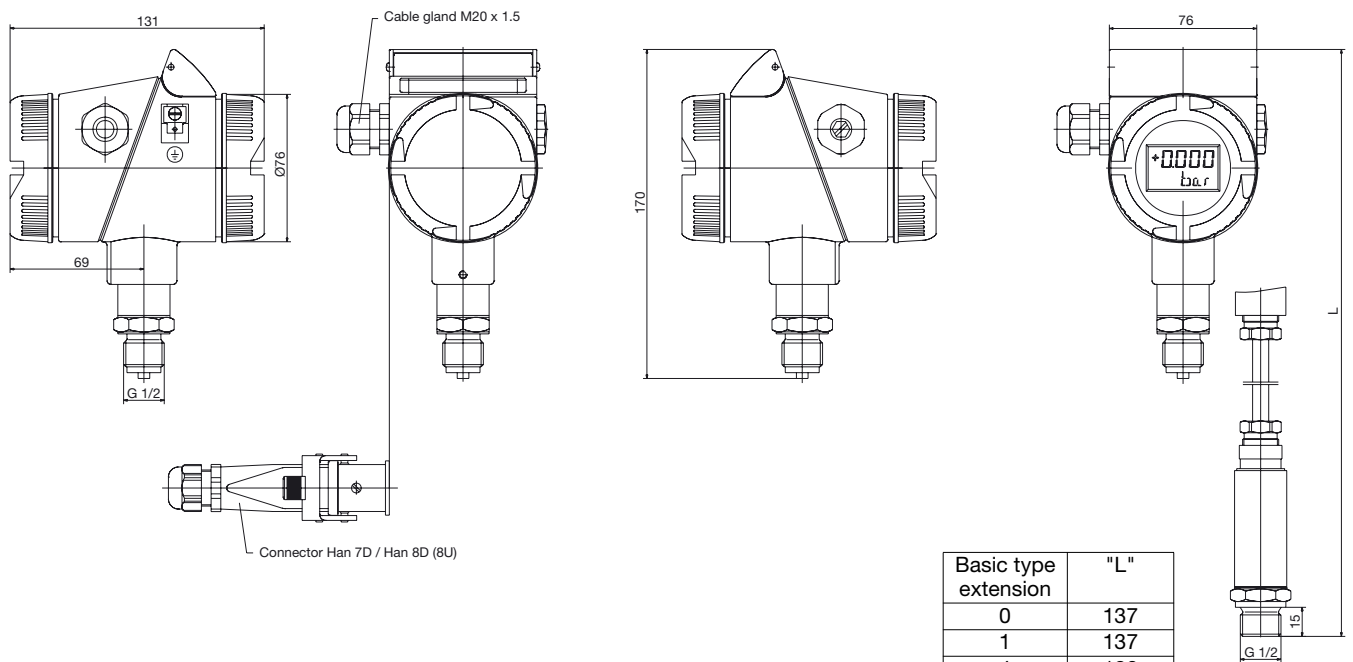

NTS 527

**Front-flush pressure connections**

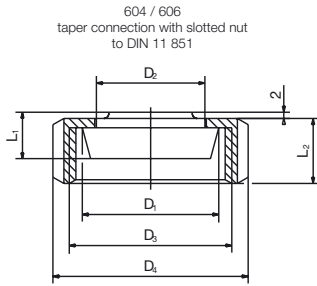

DN	D <sub>1</sub>	D <sub>2</sub>	D <sub>3</sub>	D <sub>4</sub>	L <sub>1</sub>	L <sub>2</sub>	NTS
25	ø44	ø35	RD 52x1/6	ø63	15	21	604
40	ø56	ø48	RD 65x1/6	ø78			606

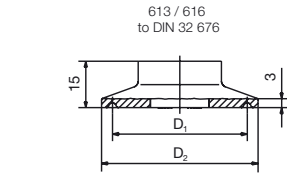

DN DIN32676	DN (inch)	Nominal Size ISO 2852	Storlek SMS 3017	D <sub>1</sub>	D <sub>2</sub>	NTS
25	1.5" 1"	25	25	ø43.5	ø50.5	613
50	2"	51	51	ø56.5	ø64	616

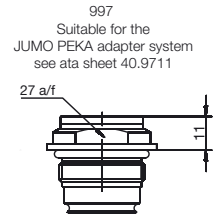
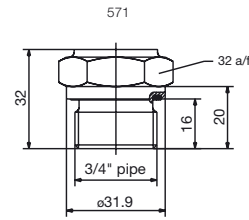

**Pressure connections, not Front-flush**

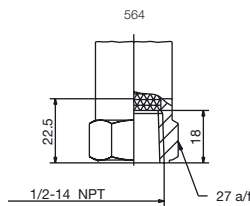
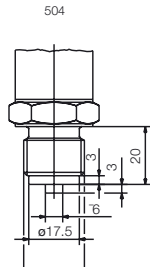
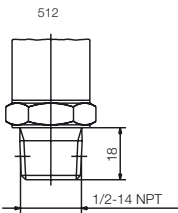

**Electrical connection**

Connection		Terminals
Supply 11.5 – 36 V 11.5 – 30 V DC for intrinsically safe version		1 L+ 2 L-
Output 4 – 20 mA 2-wire		1 L+      proportional current 4 – 20 mA 2 L-      in supply
Test connection Current output	internal resistance of the ammeter ≤ 10 Ω	TEST + TEST -
Test connection HART®		TEST + HART®
Potential equilibration (for intrinsically safe circuit)		
Screen		

**Warning:**

Earth the instrument!  
(Pressure connection and screen)

**Termination**

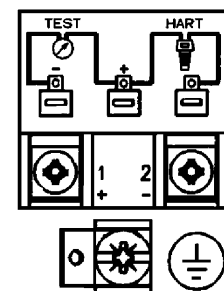

## Ordering details

### Basic type

404385

JUMO dTRANS p02 pressure transmitter with sensor element in piezo-resistive or thin-film technology

### Basic type extensions

- 0 none
- 1 with **Ex** protection Ex II 1/2G EEx ia IIC T4-T6
- 4 for increased temperature of medium up to 200°C<sup>1</sup> (for process connections 571, 604, 606, 613 and 616 only)<sup>1, 2</sup>

### Nominal range input

- 414 -100 to +100 mbar gauge pressure
- 453 -0.6 to +0.6 bar gauge pressure
- 457 -1 to +4 bar gauge pressure
- 461 -1 to +25 bar gauge pressure
- 464 -1 to +100 bar gauge pressure
- 468 -1 to +600 bar gauge pressure
- 487 -0 to +0.6 bar absolute pressure
- 491 -0 to +4 bar absolute pressure
- 495 -0 to +25 bar absolute pressure

### Output

- 405 4 – 20mA with HART® protocol

### Process connection

- 504 1/2" pipe to EN 837
- 512 1/2-14 NPT to DIN 837
- 564 1/2-14 NPT internal
- 571 3/4" pipe flush to DIN 837<sup>1</sup>
- 604 taper connection with slotted nut DN25 to DIN 11 851<sup>1,2</sup>
- 606 taper connection with slotted nut DN40 to DIN 11 851<sup>1,2</sup>
- 613 clamp connection DN 25 to DIN 32 676 <sup>1,2</sup>
- 616 clamp connection DN 50 to DIN 32 676 <sup>1,2</sup>
- 997 JUMO PEKA <sup>3</sup>

### Material for process connection

- 20 stainless steel, Mat. Ref. 1.4401
- 82 Hastelloy C276, Mat. Ref. 2.4819
- 99 special material for process connection

### Electrical connection

- 06 screw terminals
- 99 special electrical connection

### Filling medium for measuring system

- 0 none (only with input for nominal range 464 and 468)
- 1 Silicone oil <sup>1</sup>

404385 / [ ] - [ ] - 405 - [ ] - [ ] - [ ] - [ ] **Ordering code**

### Factory setting:

please specify the range to be set and the unit in plain text!

<sup>1</sup> not for nominal range -1 to 100 bar and -1 to 600 bar gauge pressure

<sup>2</sup> not for protection EEx ia II C

<sup>3</sup> suitable process connection adapter, see data sheet 40.9711