



# SERIES 90S/90F

## 90S-SPLIT BODY FLANGE BALL VALVE

## 90F-SPLIT BODY FLANGE BALL VALVE-FIRE SAFE

### STANDARD SERIES 90S/90F FEATURES

- Patent "Sealmaster " stem arrangement.
- Double stem sealing to comply with TA-LUFT requirements.
- Blow-out proof stem.
- Built-in ISO 5211 mounting pad for easy automation.
- Anti-static devices for ball-stem-body.
- Valve pressure rating : ANSI class 150/300  
DIN PN10/16/25/40  
JIS 10K/20K
- Investment casting up to 4", 5"-12" sand casting.
- Wide range of seat material selection.
- Heavy duty body & end cap construction with traceable heat number.
- Pressure balance hole in ball slot.
- Pressure self relief seat to prevent pressure built up.
- Tightness to EN12266-1



### AVAILABLE OPTIONS - 90S/90F

- Other alloys upon request with minimum quantities.
- Casting per NACE/MR-01-75 for sour gas service.
- Castings per AD-WO/TRD-100.
- Material test report per DIN 50049 3.1B form.
- High purity cleaning (oil free).
- Clean room assembly & testing.
- Vacuum service
- Oxygen service
- Fire safe application.
- Secondary metal to metal seating surface.(90F)
- Flexible graphite body and stem packing for Hiotemp resistance.(90F)
- Fire tested to API 607 4<sup>th</sup> edition up to 12"-DN300.(90F)



### DESIGN SPECIFICATION

Standard	ASME/ANSI	DIN	JIS
Rating	B16.34 class 150#	EN 1092-1 PN10~PN40	JIS B2238 10K
	B16.34 calss 300#		JIS B2238 20K
Face to Face	B16.10	DIN 3202 F4 (DN15~DN100) EN558-1 Series 27	B2002 10K Series No.6(15A~100A)
	BS 2080	DIN 3202 F5 (DN125~DN300) EN558-1 Series 27	B2002 10K Series No.39(125A~300A)
	1/2" - 12" ~	DIN 3202 F1 (DN15~DN300) EN558-1 Series 1	B2002 20K Series No.10(15A~300A)
Connection	B16.5 RF Serrated finish (Ra 3.2~6.3) BS1560 Part 2 RF	EN 1092-1 PN10~PN40 Facing EN1092 Type 21 Form B	B2238 10K B2238 20K
Inspection & testing	API 598	EN 10266-1	JIS B2003
Quality assurance	ISO 9001	ISO 9001	ISO 9001

■ PRESSURE-TEMPERATURE RATINGS FOR TV SERIES 90S/90F BALL VALVES

The pressure-temperature ratings of ball valves are determined, not only by valve shell materials, but also by sealing materials used for ball seats, stem packings, and body seal. Sealing materials may be high molecule, elasticity and hardness, however, the choice is limited by the characteristics of the service fluid, temperature, pressure, velocity of fluid, frequency of valves operation and sizes of ball valves etc. Followings are the general rating charts for non-shock fluid service for TV's floating ball valves distinguished by sizes and seating materials. A general precautions for TV's soft seated ball valves, please refer to engineering data GP-9907-1.0

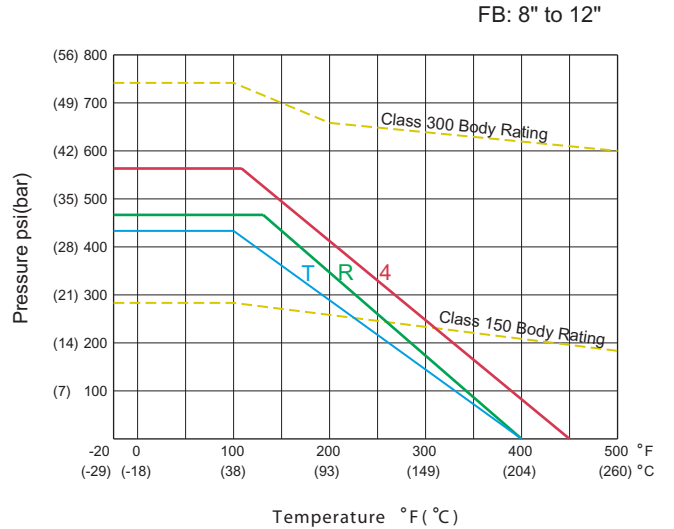
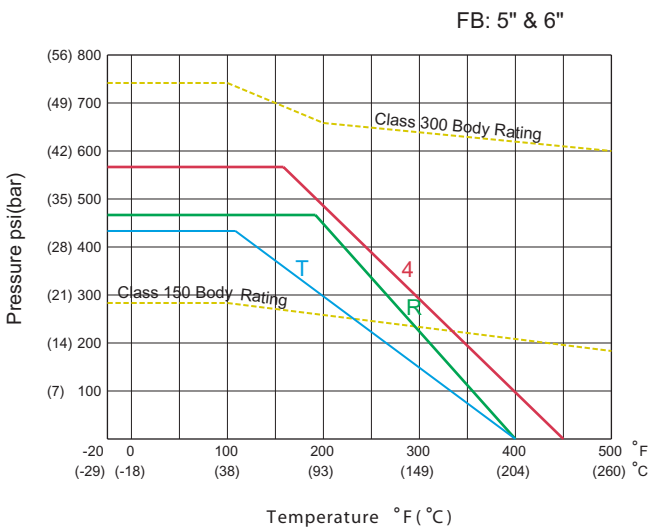
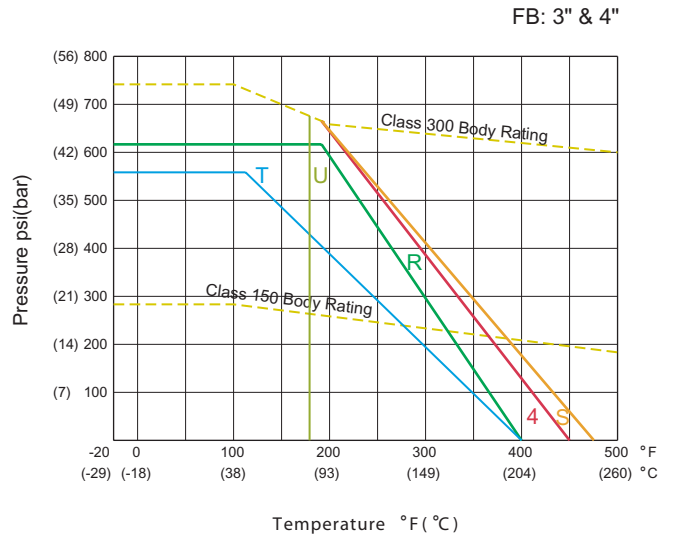
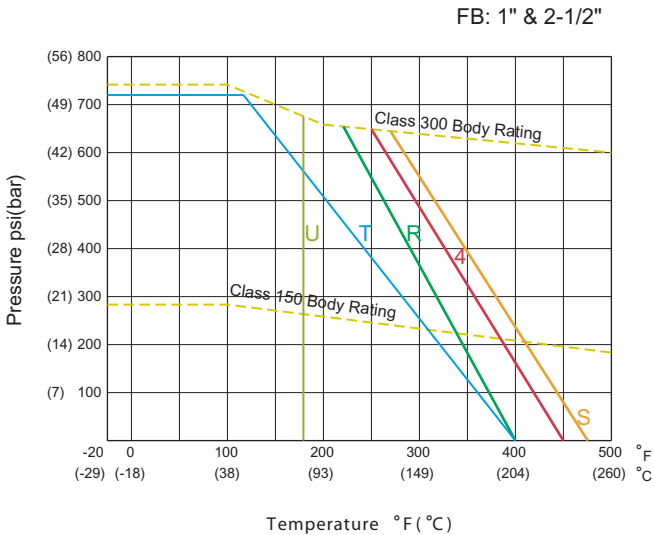
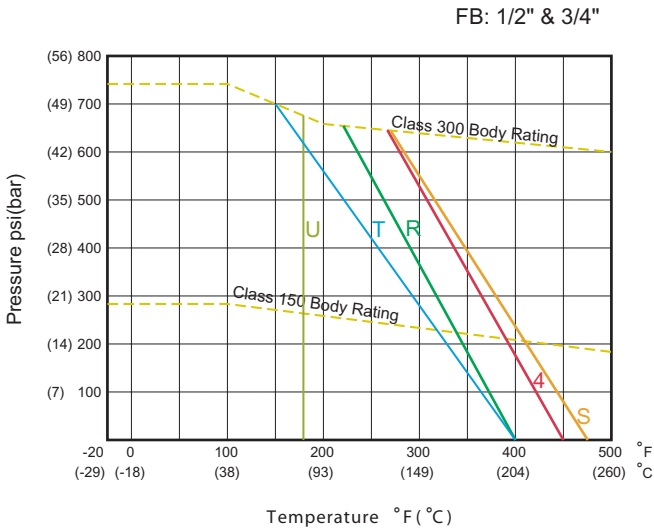

T=PTFE 4=25% CARBON FILLED PTFE  
 R=RPTFE S=50% SS FILLED PTFE U=UHMWP  
 Use Class 150 Body Rating also for DIN PN10/16&JIS10K  
 Use Class 300 Body Rating also for DIN PN25/40&JIS20K

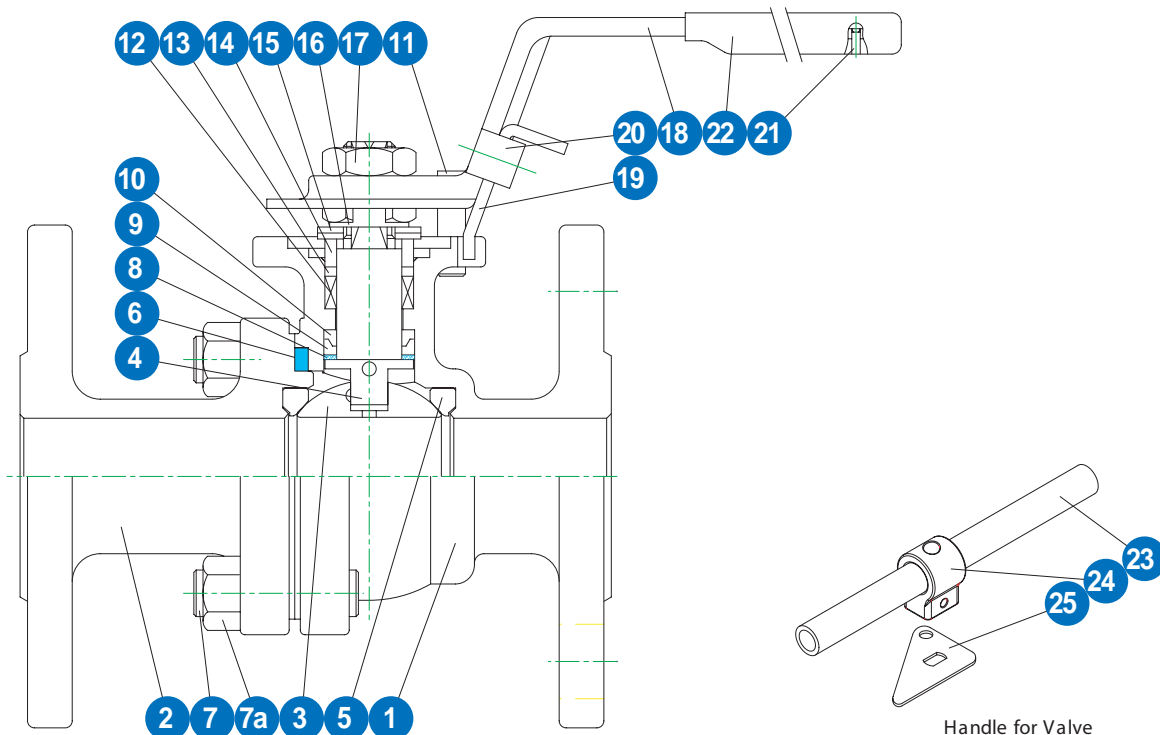

Handle for Valve  
Size DN65 to DN300  
(2-1/2" to 12")

**MATERIAL OF CONSTRUCTION**

NO	Parts Name	Material	Q'TY
1	Body	ASTM A351 Gr. CF8M / ASTM A216 Gr. WCB	1
2	Cap	ASTM A351 Gr. CF8M / ASTM A216 Gr. WCB	1
3	Ball	ASTM A351 Gr. CF8M	1
4	Anti Static Stem	A276 TYPE 316	1
5	Ball Seat	PTFE	2
6	Body Seal	PTFE	1
7	Stud	A193 Gr. B8/ A193 Gr. B7	4
7a	Nut	A194 Gr.8/A194 Gr 2H	6-20
8	Lower Stem seal	50% SS powder/50%PTFE	1
9	Compress Ring	316SS	1
10	Upper Stem Seal	TFM1600	1
11	Stop Bolt	Stainless Steel	1
12	V-Ring Stem Packing	PTFE	1 set
13	Thrust Washer	50% SS Powder/50%PTFE	1
14	Gland	304SS	1
15	Bellville Washer	301SS	2
16	Lock Saddle	304SS	1
17	Stem Nut	304SS	2
18	Handle (1/2"-2")	CF8	1
19	Locking Trigger	304SS	1
20	Fix Plate	304SS	1
21	Rivet	304SS	2
22	Handle Sleeve	VINYL	1
23	Handle(2 1/2"-12")	SGP Zn Plating	1
24	Handle Adapter (2 1/2"-12")	CF8(2 1/2"-5")/ A536 (6"-12")	1
25	Triangle Stopper(2 1/2"-12")	304SS	1

\* For DIN valves, the body & cap material will be 1.4408/1.0619  
 \* For JIS valves, the body & cap material will be SCS14A/SCPH2.

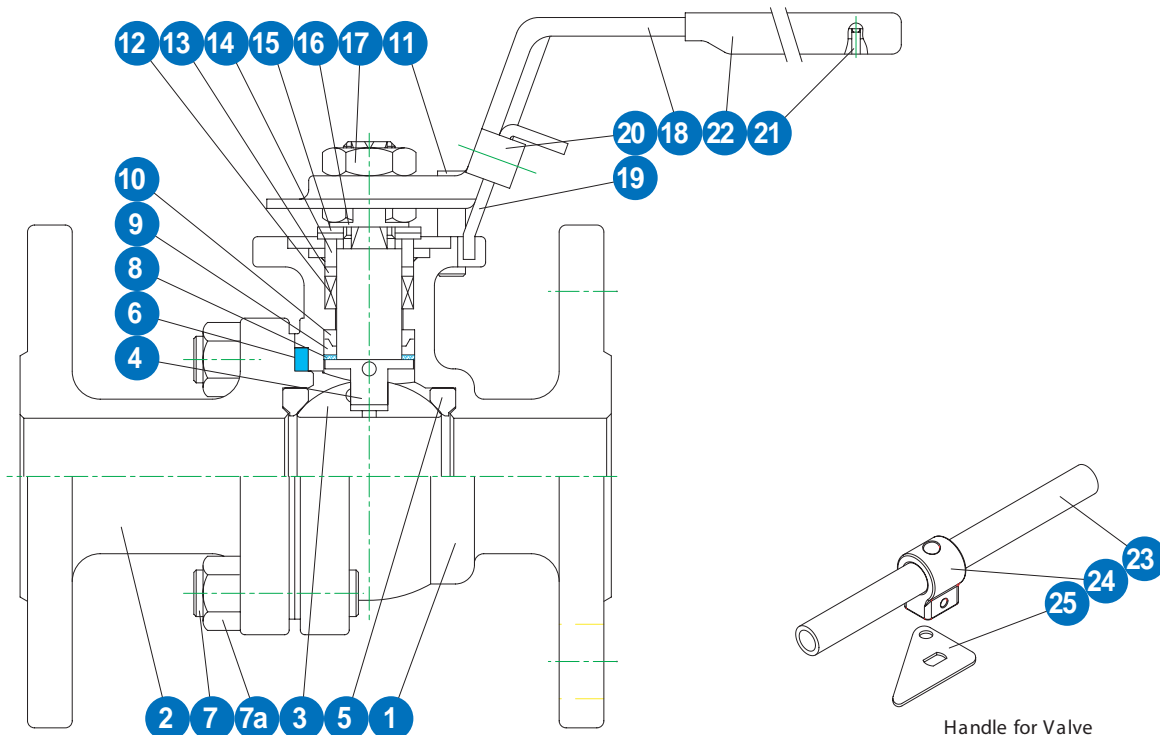

Handle for Valve  
Size DN65 to DN300  
(2-1/2" to 12")

**MATERIAL OF CONSTRUCTION**

NO.	PART NAME	MATERIAL	Q'TY
1	Body	ASTM A351 Gr. CF8M / ASTM A216 Gr. CF8M	1
2	Cap	ASTM A351 Gr. CF8M / ASTM A216 Gr. CF8M	1
3	Ball	ASTM A351 Gr. CF8M	1
4	Anti Static Stem	A276 TYPE 316	1
5	Ball Seat	PTFE	2
6	Body Seal	SS316 Spiral Wound Grafoil	1
7	Stud	A193 Gr.B8 / A193 Gr.B7	4
7a	Nut	A194 Gr.8 / A194 Gr.2H	6-20
8	Lower Stem Seal	50% SS Power / 50% PTFE	1
9	Compress Ring	316SS	1
10	Upper Stem Seal	Grafoil	1
11	Stop Bolt	Stainless Steel	1
12	Stem Packing	Grafoil	1 SET
13	Thrust Washer	50% S.S Power / 50% PTFE	1
14	Gland	304SS	1
15	Belleville Washer	301SS	2
16	Lock Saddle	304SS	1-2
17	Stem Nut	304SS	1
18	Handle (1/2"-2")	CF8	1
19	Locking Trigger	304SS	1
20	Fix Plate	304SS	1
21	Rivet	304SS	2
22	Handle Sleeve	Vinyl	1
23	Handle(2 1/2"-12")	SGP Zn Plating	1
24	Handle Adapter	CF8(2 1/2"-5") / A536 (6"-12")	1
25	Triangle Stopper(2 1/2"-12")	SUS304	1

\* For DIN valves, the body & cap material will be 1.4408/1.0619  
 \* For JIS valves, the body & cap material will be SCS14A/SCPH2.

**■ Fire tested to API 607 4" edition on TV's 90F soft-seated flanged ball valve**

Plant fires are serious concern for soft-seated ball valve especially when the flammable fluids or dangerous gases are in service. The possible flammable fluid leakage during the fire is consequently increase the fire magnitude and make the situation worsen.

TV's floating ball valves are designed to be fire safe to minimize both external and internal fluid leakage after plant fires due to:

- Contact between ball and fire safe lip for through leakage prevention. During a fire, the soft seats are destroyed and the ball is free to move to downstream to form metal to metal contact between the ball and the end cap fire safe lip. This lip is integral part for end both cap and body which has very tight clearance with the ball. (See fig. #1 & #2)
- To maintain the integrity between end cap and body, our independent flange bolts or studs are screwed to body. It eliminates the joint from thermal expansion and contraction resulted from the fire and make fire resistance encapsulated grafoil body gasket to function as the way it should be and prevent the line fluid permeation and resultant leakage to external. (See fig. #3 & #4)
- Stem packing, seal arrangement remained unaffected due to grafoil material for fire resistance. (See Fig #5 & #6)

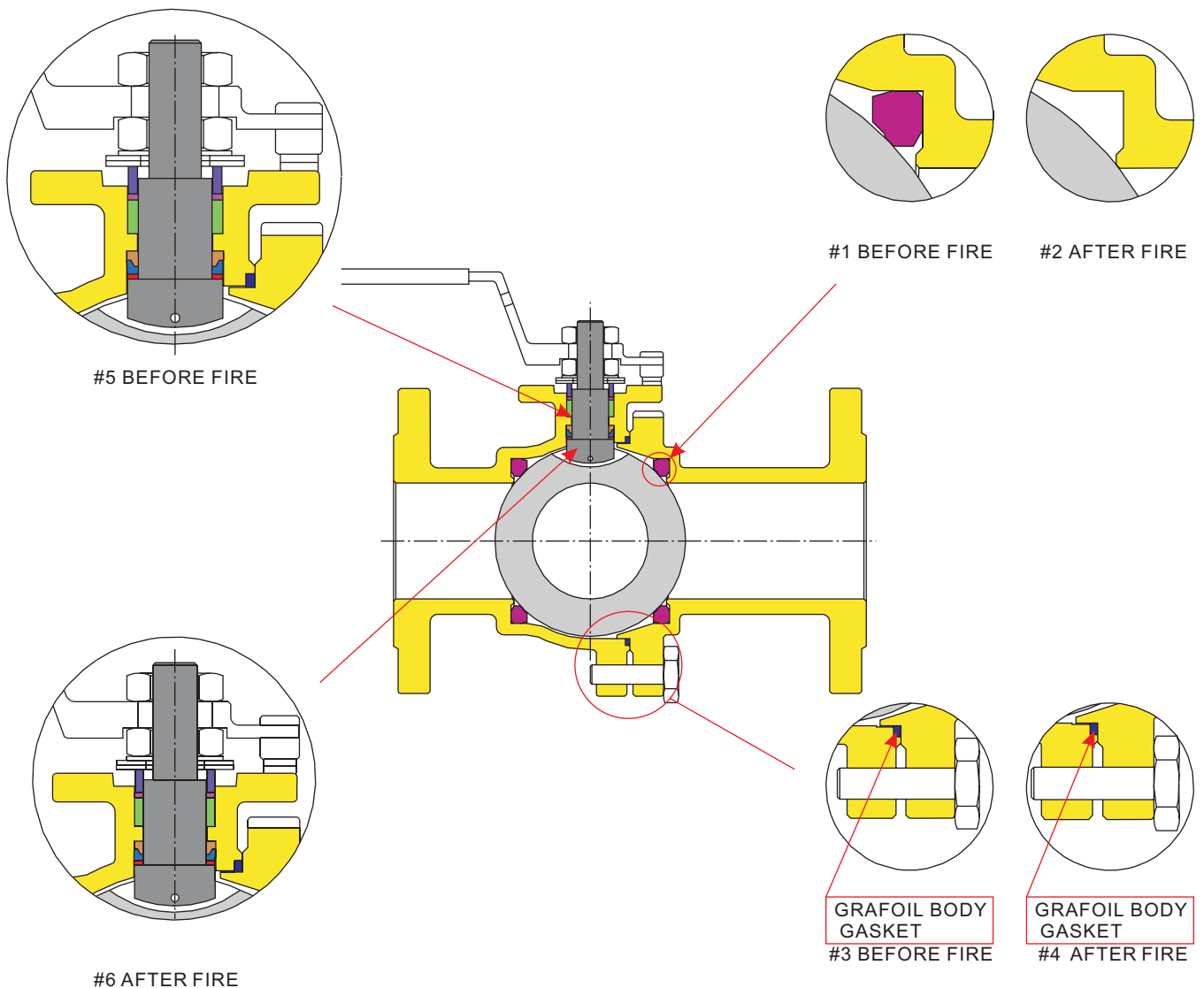

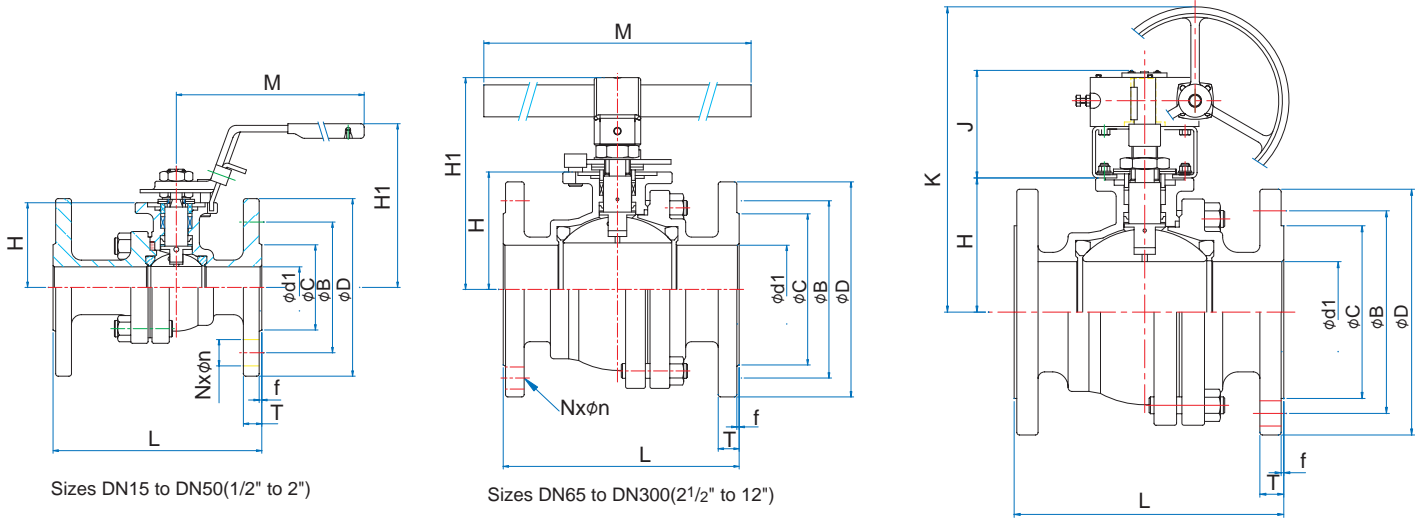

Sizes DN15 to DN50(1/2" to 2")

Sizes DN65 to DN300(2 1/2" to 12")

Sizes DN125 to DN300(5" to 12") optional

**Common dimensions for 90S/90F series**

Size	DN	A	øP	F	G	B	W	M	H	H1	J	K
1/2"	15	20.3	42	9.7	6.3	12.0	M5	135	38.5	82	N/A	N/A
3/4"	20	20.5	42	9.7	6.3	12.4	M5	135	42.0	86	N/A	N/A
1"	25	21.6	50	11.2	8.0	14.0	M6	165	51.5	98	N/A	N/A
1 1/4"	32	21.6	50	11.2	8.0	14.0	M6	165	56.2	102	N/A	N/A
1 1/2"	40	26.0	70	16.0	9.5	16.2	M8	200	65.5	119	N/A	N/A
2"	50	26.0	70	16.0	9.5	16.2	M8	200	74.5	128	N/A	N/A
2 1/2"	65	43.0	102	22.3	17.0	24.7	M10*	495	88.0	162	N/A	N/A
3"	80	43.5	102	22.3	17.0	25.2	M10*	495	101.0	172	N/A	N/A
4"	100	49.0	102	28.6	17.0	30.0	M10*	595	122.0	197	N/A	N/A
5"	125	53.6	102	28.6	17.0	33	M10*	595	140.0	226	161	393
6"	150	65.0	125	34.0	23.0	39	M12	800	167.0	281	190	513
8"	200	65.0	125	34.0	23.0	39	M12	1100	203.0	317	190	549
10"	250	83.5	140	50.0	30.0	52	M16	1100	263.0	378	221	625
12"	300	83.5	140	50.0	30.0	52	M16	1100	305.0	420	221	667

\* For 2 1/2"~5" JIS 10K/20K, W=M12

**ANSI CLASS 150 & ANSI CLASS 300**

Size	DN	øB		øD		L		N		T		øn		øC	ød1	f	Wt(kg)	
		150	300	150	300	150	300	150	300	150	300	150#	300#					
1/2"	15	60.5	66.5	89.0	95.0	108.0	140.0	4	4	11.2	14.3	16.0	16.0	35	15	1.6	1.82	2.20
3/4"	20	70.0	82.5	98.6	117.0	117.0	152.0	4	4	11.2	15.9	16.0	19.0	43	20	1.6	2.12	3.25
1"	25	79.5	89.0	108.0	124.0	127.0	165.0	4	4	11.2	17.5	16.0	19.0	51	25	1.6	3.04	4.48
1 1/2"	40	98.5	114.5	127.0	156.0	165.0	190.0	4	4	14.2	20.7	16.0	22.0	73	40	1.6	5.80	8.70
2"	50	120.5	127.0	152.5	165.0	178.0	216.0	4	8	15.9	22.3	19.0	19.0	92	50	1.6	8.36	11.20
2 1/2"	65	139.5	149.0	178.0	190.0	190.0	241.0	4	8	17.5	25.4	19.0	22.0	105	65	1.6	15.00	19.00
3"	80	152.5	168.0	190.5	210.0	203.0	283.0	4	8	19.1	28.6	19.0	22.0	127	76	1.6	19.92	28.00
4"	100	190.5	200.0	229.0	254.0	229.0	305.0	8	8	23.9	31.8	19.0	22.0	157	100	1.6	32.90	43.72
5"	125	215.9	234.9	254.0	279.4	355.6	381.0	8	8	23.8	34.9	22.2	22.2	186	125	1.6	49.00	71.00
6"	150	241.3	269.9	279.4	317.5	393.7	403.4	8	12	25.4	36.6	22.2	22.2	216	150	1.6	75.00	100.00
8"	200	298.4	330.2	342.9	381.0	457.2	501.7	8	12	28.6	41.3	22.2	25.4	270	200	1.6	128.00	172.00
10"	250	361.9	387.3	406.4	444.5	533.4	568.5	12	16	30.2	47.6	25.4	28.6	324	250	1.6	215.00	291.00
12"	300	431.8	450.8	482.6	520.7	609.6	647.7	12	16	31.8	50.8	25.4	31.8	381	300	1.6	254.00	423.00

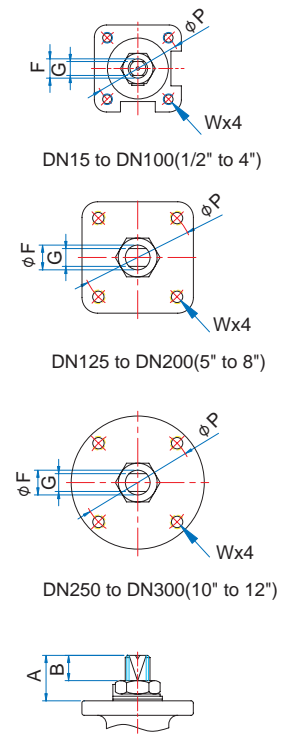

**■ DIN PN10/16/25/40**

DN	Size	PN	øB	øC	øD	L	*L	N	T	øn	ød1	f	Wt (kg)	
													F1	F4/F5
DN15	1/2"	10/16/25/40	65	45	95	115	130	4	16	14	15	2	2.42	2.46
DN20	3/4"	10/16/25/40	75	58	105	120	150	4	18	14	20	2	3.24	3.08
DN25	1"	10/16/25/40	85	68	115	125	160	4	18	14	25	2	4.42	4.18
DN32	1 1/4"	10/16/25/40	100	78	140	130	180	4	18	18	32	2	6.10	5.62
DN40	1 1/2"	10/16/25/40	110	88	150	140	200	4	18	18	40	3	7.94	7.40
DN50	2"	10/16/25/40	125	102	165	150	230	4	20	18	50	3	10.50	9.76
DN65	2 1/2"	10/16	145	122	185	170	290	4	18	18	65	3	17.00	16.60
		25/40	145	122	185	170	290	8	22	18	65	3	18.30	16.22
DN80	3"	10/16	160	138	200	180	310	8	20	18	80	3	21.50	21.40
		25/40	160	138	200	180	310	8	24	18	80	3	24.90	21.34
DN100	4"	10/16	180	158	220	190	350	8	20	18	100	3	34.00	27.72
		25/40	190	162	235	190	350	8	24	22	100	3	37.20	31.42
DN125	5"	10/16	210	188	250	325	400	8	22	18	125	3	50.00	48.00
		25/40	220	188	270	325	400	8	26	26	125	3	60.00	57.00
DN150	6"	10/16	240	212	285	350	480	8	22	22	150	3	78.00	73.00
		25/40	250	218	300	350	480	8	28	26	150	3	92.00	82.00
DN200	8"	10	295	268	340	400	600	8	24	22	200	3	124.00	98.00
		16	295	268	340	400	600	12	24	22	200	3	124.00	98.00
		25	310	278	360	400	600	12	30	26	200	3	164.00	148.00
		40	320	285	375	400	600	12	34	30	200	3	164.00	148.00
DN250	10"	10	350	320	395	450	730	12	26	22	250	3	270.00	203.00
		16	355	320	405	450	730	12	26	26	250	3	270.20	203.00
DN300	12"	10	400	370	445	500	850	12	26	22	300	4	N/A	233.00
		16	410	378	460	500	850	12	28	26	300	4	N/A	233.00

L Dimensions 1/2" to 4" F4, 5" to 12" F5.

\*L Dimensions 1/2" to 12" F1.

\*\* For DN65 on PN 25/40 F1, Please consult factory.

**■ JIS 10K & 20K**

Size	øB		øC		øD		L		N		T		ø n		J	K	ød1	f	H	Wt(kg)		
	10K	20K	10K	20K	10K	20K	10K	20K	10K	20K	10K	20K	10K	20K						10K	20K	
15A	1/2"	70	70	51	51	95	95	108	140	4	4	12	14	15	15	N/A	N/A	15	1	38.5	2.10	2.36
20A	3/4"	75	75	56	56	100	100	117	152	4	4	14	16	15	15	N/A	N/A	20	1	42.0	2.50	2.80
25A	1"	90	90	67	67	125	125	127	165	4	4	14	16	19	19	N/A	N/A	25	1	51.5	3.86	4.55
32A	1 1/4"	100	N/A	76	N/A	135	N/A	140	N/A	4	N/A	16	N/A	19	N/A	N/A	N/A	32	2	56.2	5.50	N/A
40A	1 1/2"	105	105	81	81	140	140	165	190	4	4	16	18	19	19	N/A	N/A	40	2	65.5	6.48	7.16
50A	2"	120	120	96	96	155	155	178	216	4	8	16	18	19	19	N/A	N/A	50	2	74.5	8.40	8.92
65A	2 1/2"	140	140	116	116	175	175	190	241	4	8	18	20	19	22	N/A	N/A	65	2	90.0	13.80	15.50
80A	3"	150	160	126	136	185	200	203	283	8	8	18	22	19	23	N/A	N/A	80	2	101.0	18.60	23.24
100A	4"	175	185	151	160	210	225	229	305	8	8	18	24	19	23	N/A	N/A	100	2	122.0	27.36	34.10
125A	5"	210	225	185	195	250	270	356	381	8	8	20	26	23	25	161	393	125	2	140.0	46.00	69.00
150A	6"	240	260	212	230	280	305	394	403	8	12	22	28	23	25	190	513	150	2	167.0	73.00	92.00
200A	8"	290	305	262	275	330	350	457	502	12	12	22	30	23	25	190	549	200	2	203.0	120.00	139.00
250A	10"	355	380	324	345	400	430	533	568	12	12	24	34	25	27	221	625	250	2	263.0	201.00	291.00
300A	12"	400	430	368	395	445	480	610	648	16	16	24	36	25	27	221	667	300	3	305.0	254.00	423.00

**■ ORDERING INFORMATION**

**90S** FLANGE FULL PORT SS316 RPTFE 1-1/2" ANSI300 OVAL HANDLE  
**90F** - **F** **1** **1** **R** **G** - **B** **5**

END CAP TYPE		PORT TYPE		BODY/END CAP MATERIAL		SEAT MATERIAL		SIZE				PRESSURE		HANDLE TYPE	
F	FLANGE	1	FULL PORT	1	316 CF8M 1.4408 SCS14	T	PTFE	C	1/2"	K	3"	A	ANSI 150	1	STANDARD HANDLE W/LOCK
				4	WCB GS-C25 1.0619	R	RPTFE	D	3/4"	L	4"	B	ANSI 300	2	T-HANDLE
				5	316L CF3M	M	MG1241	E	1"	M	5"	E	PN10/16 F1	3	BARE SHAFT
				O	OTHER	4	25% CARBON	F	1-1/4"	N	6"	F	PN25/40 F1	4	OTHERS
						U	UHMWPE	G	1-1/2"	P	8"	G	PN10/16 F4/F5	5	GRAE BOX
						S	50% S.S./50% PTFE	H	2"	Q	10"	H	PN25/40 F4/F5		
						O	OTHER	J	2-1/2"	R	12"	L	JIS 10K		
												M	JIS 20K		